



The information and data contained in this document were prepared by a technical committee of the Association. The committee and the Association assume no liability or responsibility in connection with the use of such information or data, including but not limited to any liability or responsibility under patent, copyright, or trade secret laws. The user is responsible for determining that this document is the most recent edition published.

Viscosity of coating clay slurry

1. Scope

1.1 This method describes a procedure for the determination of the low- and high-shear viscosity of coating clays. This is accomplished by the preparation of a completely dispersed 70% solids aqueous clay suspension with incremental introduction of a dispersing chemical to obtain the optimum dosage (minimum viscosity) for the low and high shearing rates.

1.2 At 70% solids content, not all clay slurries are sufficiently fluid to permit viscosity determinations with the usual instruments. The test as written is thus substantially limited in its applicability to the type of coating clays suitable for high solids coating. A similar test procedure using lower solids content is informative in the case of clays not suited to testing at 70% solids, but in each case the solids content should be maintained at as high a level as possible to accentuate differences between the clays in question.

1.3 Coating clays are available in predispersed slurry form, generally at 69.5 – 70.5% solids. The procedure for determining the viscosity characteristics of these clay slurry shipments is also incorporated in this method.

2. Significance

Aqueous clay slurries usually display non-Newtonian types of flow. It is therefore necessary to control carefully the rate of shear in order to measure flow properties reproducibly. Because the viscosity varies with the rate of shear, it is highly desirable to measure flow properties at low and high shearing rates. Unfortunately, no single instrument is readily available that will measure viscosity under both conditions. A rotating spindle apparatus operating at a maximum torque of 0.7187 mN·m (7187 dyne-cm) is used for low-shear measurements. A rotating bob apparatus calibrated to measure torque in 10 mN·m (dyne-cm x 10⁵) at increasing shear rates up to a maximum of 4540 s⁻¹ is used for high shear measurements. Both instruments give reproducible results and have been selected arbitrarily as standard instruments for this test method.

3. Apparatus

3.1 *Low-shear viscometer*¹, a rotating spindle apparatus with a full-scale spring torque, 0.7187 mN·m (7187 dyne-cm) and operating at 20 rpm with an appropriate spindle for mid-scale readings, as shown in Fig. 1 and fully described in the appendix. This instrument can be operated at 10, 20, 50, and 100 rpm spindle speed. Viscosity values obtained at these four spindle speeds may be helpful in determining differences in rheological properties of various samples since it is not unusual for samples to have similar values at a given spindle speed but differ significantly at other speeds. In general, the 20-rpm value is the one normally referred to in pigment product specifications.

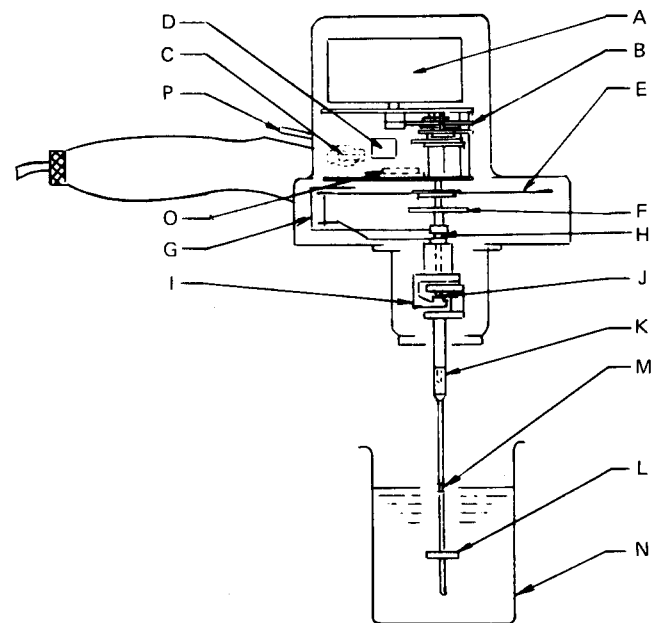

Fig. 1. Low-shear viscometer.

¹Names of suppliers of testing equipment and materials may be available from the TAPPI Information Resources Administrator.

3.2 *High-shear viscometer*¹, a high-shear rotational bob instrument equipped with necessary accessories, as shown in Fig. 2 and fully described in the Appendix.

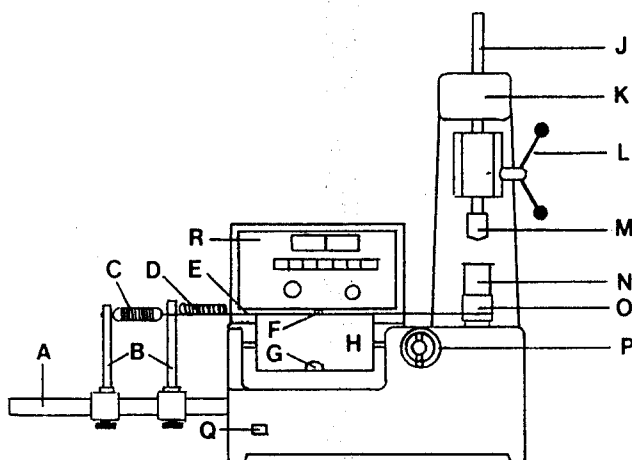

Fig. 2. High-shear viscometer.

3.3 *Heavy-duty high-speed mixer*, a variable speed mixer capable of developing a peripheral speed under load of about 1068 m/min (3500 ft/min) in a container having a 1:2.4 impeller-container diameter ratio and positioned so that the mixer blades are immersed to within 1–1.5 cm of the inside bottom of the mixing cup.

3.3.1 *Malted milk-type mixer*, high speed, with a 107-W (1/7 hp), 20,000-rpm motor, and equipped with a four-blade folding impeller about 32.5 mm (about 1.25 in.) diameter with accompanying round mixing cup, is satisfactory for most applications.

3.4 *Mixer*, low-speed, laboratory variable speed to 2000 rpm, with 50 mm (2 in.) slotted type propeller, to be used to incorporate any necessary dilution water and/or dispersant additions to the prepared pigment suspension during solids adjustment or during incremental dispersant additions as described under Section 7.

3.5 *Oven*, maintained at $105 \pm 3^\circ\text{C}$ ($221 \pm 5^\circ\text{F}$).

3.6 *Beaker*, 600 mL tall form (Berzelius).

3.7 *Miscellaneous*: balance, with a capacity of 2000 g; 74- μm (200-mesh) sieve; thermometer graduated from 0 to 100°C ; beakers, 600-mL.

4. Calibration

4.1 *Low-shear viscometer*. Calibrate the instrument with the standard viscosity oils, available from the instrument manufacturer, using the same spindle, volume, and temperature, and similar container employed for the sample. Draw a calibration curve for the instrument based on at least two standard oils having higher and lower viscosities than the sample being measured. If the measured viscosity of the

standard oil with an established factor differs by less than 2% from that given for the standard oil, the viscosity of the specimen may be found by applying a proportionate correction factor. If the difference is more than 2%, have the instrument reconditioned by the manufacturer before use.

4.2 *High-shear viscometer*. Calibrate the instrument with a manufacturer's certified test fluid. A rheogram of the fluid is determined with the A bob, 1.0 Nm/m (100,000 dyne-cm/cm) spring set and a 0–1100 rpm bob speed range according to the manufacturer's operating instructions. The apparent viscosity of the test fluid should agree within $\pm 1\%$ of the certified value. If the difference is more than $\pm 1\%$, a new factory-calibrated 1.0-Nm/m spring set should be installed.

5. Reagents and materials

5.1 *Dispersing agent*, tetrasodium pyrophosphate, $\text{Na}_4\text{P}_2\text{O}_7$, or a freshly prepared 50% solution, by weight, of sodium hexametaphosphate (NaPO_3)₆ in deionized or distilled water.

5.2 *Standard viscosity oils and fluids* having a certified viscosity range.

NOTE 1: Do not keep these oils beyond the period specified by the supplier, since their viscosities tend to change with time.

6. Sampling and test specimen

Obtain approximately 600 g of clay in accordance with TAPPI T 657 "Sampling of Fillers and Pigments." After determining the moisture content in accordance with TAPPI T 671 "Free Moisture in Fillers and Pigments," weigh out the equivalent of 550 ± 0.1 g of moisture-free clay as the test specimen.

7. Procedure

7.1 Pour 235 g of water, minus the free water contained in the 550-g clay specimen itself, into a tared mixer cup. Add the equivalent of 0.2% of dispersant on the dry weight of the clay to the water in the mixing cup (for slurry samples, see 7.3). If the clay is in "predispersed" form, this dispersant addition step should be omitted. Place the cup on either of the high-speed mixers and start the motor at low speed, adding the clay in small increments and allowing it to mix thoroughly between additions. The clay specimen addition is normally accomplished within a 2–3-min period. When all the clay has been added, agitate the mixture at high speed for 15 min, then remove the cup from the mixer, cover with a watch glass and cool in a water bath to $26 \pm 0.5^\circ\text{C}$.

7.2 Determine the percent solids of the cooled slurry by evaporating to dryness approximately 10 g of slurry in the drying oven and weighing the residue to constant weight.

NOTE 2: If the percent solids of the clay-water suspension is less than the desired 70% solids, it will be necessary to repeat the test — taking care that the free moisture content of the clay used in preparing the slurry has been determined accurately. This initial slurry percent solids determination is of prime importance since the solids value obtained will be used to determine the dilution water required to adjust the slurry sample to the desired solids as discussed in 7.4.

NOTE 3: It is also important to measure accurately the dosage of dispersing reagent added, because small differences from the optimum may cause large differences in the resulting viscosity.

7.3 In the case of clay slurry shipment, mix slurry samplings for 2 min with the low-speed mixer. Following this, determine the percent solids of the slurry as prescribed, and conduct testing in accordance with the prescribed procedure below for both slurry and dry clay situations.

NOTE 4: In the case of these preslurried clays, omit the various steps concerned with making the clay into full dispersions, as the supplier has already performed this task; however, the procedure outlined for determining the optimum amount of dispersant required to achieve minimum viscosities should be followed.

7.4 Screen the remaining slurry through the 74- μm (200-mesh) sieve. Transfer a quantity of slurry equivalent to 500 g moisture-free dry clay into the tared 600-mL beaker and adjust the solids to exactly 70.0% by the addition of water. Adjust the temperature of the mixture to $26 \pm 0.5^\circ\text{C}$, then mix 2 min with the low-speed mixer at a speed setting just sufficient to result in a gentle surface movement of the slurry towards and down into the vortex resulting from the stirring action.

7.5 Measure the low-shear viscosity on the viscometer at 20 rpm using an appropriate spindle by the following technique so as to produce a scale reading on the viscometer between 30 and 70% of full-scale deflection. Immerse the spindle in a slightly tilted state until the spindle disc is completely submerged, thus preventing entrapment of air beneath the disc which could affect the accuracy of values obtained. After the disc is submerged, straighten the spindle shaft to a vertical position. Connect the spindle to the viscometer and lower the spindle to the correct shaft immersion mark. Set the speed control knob, depress the viscometer's clutch, and start the motor. Release the clutch and allow the unit to rotate for 30 s. Depress the clutch, stop the motor, and take the torque reading from the pointer's location on the instrument scale. Convert the torque reading to viscosity in mPa·s using the conversion chart provided with the instrument.

7.6 After making low-shear viscosity measurements, pour enough slurry into the high-shear viscometer cup

(which, with the bob, has been cleaned, adjusted to about 26°C , and dried) to barely cover the A bob after it is lowered into position. Turn on the instrument and measure the torque to 1100 rpm or 0.18 Nm ($18 \text{ dyne-cm} \times 10^9$) using the 1.0 Nm/m spring set. Uniformly increase the bob speed to 1100 rpm and return to 0 rpm in 42 s, or to that speed at which the maximum torque limits have been reached as indicated by the pen travel to the right-hand vertical margin of the graph paper. For those using the newer "automatic" units, the speed increase and decrease is controlled automatically.

NOTE 5: For those who may have the newest model high-shear viscometer and wish to utilize its higher shear rate capabilities, the rotating bob speed range of 0–4400 rpm may be used in conjunction with the appropriately sized bob and spring set as recommended in the instrument operational instructions.

7.7 Transfer all of the slurry from the bob and the viscometer cup back into a 600-mL beaker. Add an increment of dispersant to the slurry equal to 0.05% dispersant by weight, based on the dry clay content and mix at medium speed with the laboratory variable speed mixer (without pulling excessive air into the vortex) for 5 min. Repeat the viscosity measurements at low and high shear until a dispersant dosage equal to 0.10% above the amount required for optimum low-shear viscosity has been added.

8. Calculation

8.1 The apparent viscosity at any point on the rheogram from 0–1100 rpm bob speed can be calculated in poises using the following equation:

$$N = 9.55 T S / \text{rpm}$$

where

N = viscosity, poise

T = torque (deflection in cm \times spring rating in dynes)

S = instrument constant of bob (supplied by manufacturer)

Conversion to SI units: (value in Pa·s) = 0.1 \times (value in poise)
where

Pa·s = pascal second

8.2 Low-shear viscometer calculations are described in 7.5.

9. Report

9.1 Report the following items:

9.1.1 Low shear minimum viscosity in mPa·s at 20 rpm.

9.1.2 High-shear minimum viscosity at either:

9.1.2.1 Torque of 10 mN·m ($\text{dyne-cm} \times 10^9$) at 1100 rpm bob speed, or

9.1.2.2 Bob speed in rpm at which the maximum torque of 0.18 Nm (18 dyne-cm x 10⁵) is obtained, or

9.1.2.3 Submit another rheogram.

9.1.3 Type and percentage dispersant dosage on the dry weight of clay used to obtain these minimum viscosities.

9.1.4 Percent solids of the dispersant tested.

9.1.5 Initial temperature of the sample.

9.1.6 Statement that the viscosity was determined according to the present method.

10. Precision

Round-robin results have shown that the following precision may be expected on aliquot portions of a given sample for both high- and low-shear measurements: repeatability (within a laboratory) = ±5.0%; reproducibility (between laboratories) = ±10.0%.

11. Additional Information

11.1 Effective date of issue: April 20, 1988.

11.2 This method was first published in 1954 as a Suggested Method and was revised in 1972. This version differs from T 648 su-72 primarily in small editorial changes, the use of SI units, and clarification of the actual mechanics of this procedure in order to provide better understanding.

11.3 Pigments other than coating clays may be evaluated using this method with slight modifications. For instance, when evaluating alumina pigments, the basic procedure is used with the understanding that minimum viscosities are not attained with a specific dispersant dosage. Continued additions of dispersant result in continuing viscosity value decreases with some dispersants.

11.4 Dispersant requirements for minimum viscosity values differ for low- and high-shear viscometers. Generally, low-shear minimum viscosity values are obtained at lower dispersant levels than are required for high-shear values.

11.5 Various dispersants may be evaluated using this procedure. In such cases the dispersant being tested is used instead of those previously specified. In the event that two or more dispersants are being compared, they should be added at the same aqueous concentrations, if possible, thus minimizing differences that might otherwise result from slightly different solids content of the pigment slurries being tested.

11.6 *Principle of operation.*

11.6.1 Fluids have internal friction that tends to dampen motion unless force is applied continually. If two planes are moved parallel to each other, the force per unit area is a function of the velocity gradient, that is, the difference in velocity of these planes divided by the distance of separation.

11.6.2 Most viscometers are concerned with measuring the ratio of the force per unit area, known as the shearing stress, to the shear rate. This ratio, if CGS units are used, is called the viscosity in poises. Shearing is accomplished in the case of the rotational viscometers by introducing a rotating member. To calculate viscosity from the measured torque at a known rotation rate, the shape of the vessel and rotating member must be such that the rate of shear can be determined easily and in ideal cases is constant over the volume of the sample. The two types of systems which provide simple geometry are (1) coaxial cylinders, one fixed and the other moving and (2) cone and plate viscometers.

11.6.3 *Low-shear measurements.* The viscometer used for low shearing rates of 100 rpm or less contains a constant speed synchronous motor, which activates a gear train containing a shift mechanism that permits one to operate the instrument spindle at several available speeds. To determine the viscosity of a clay-water suspension, a spindle immersed in the suspension rotates at a selected speed. By a special device, the torque on the spindle acts against a calibrated spring and deflects an indicator which rotates with the scale. A clutch mechanism can be used to hold the scale firmly to the indicator so that an accurate reading may be made when the rotation is stopped. The spring constant, geometry, and size of the spindle and rotational speed are required to calculate the apparent viscosity. These values are tabulated in the table of constants supplied with each instrument.

NOTE 6: In the case of non-Newtonian liquids, the geometry of this instrument is such that it is impossible to determine the actual rate of shear in the fluid.

11.6.4 *High-shear rheological measurements.* Several models of this viscometer may be used for measuring high-shear rheology of slurried clays. The older models are powered by a constant speed synchronous motor connected to a variable speed gear train which, in turn, is connected by a series of timing belts and pulleys to a rotor (bob). The speed of this variable speed gear train manually or, in the newer models, is automatically varied at a constant rate from 0-1100 rpm rotor speed. The newest model is driven by a DC servo motor which, in turn, is geared directly to the spindle shaft by pulleys and a timing belt. The speed of the rotor is automatically increased at a constant rate to the desired rpm by a microprocessor. A recording drum, found on all models, which is wrapped with a sheet of graph paper graduated in centimeters, is simultaneously rotated to record corresponding rotor rpm values.

11.6.5 The bob or rotor assembly is lowered by a rack and pinion gear into a cup or stator which has a narrow calibrated clearance. The cup is mounted into a freely turning receiver which is mounted on ball bearings to the base of the

instrument.

11.6.6 A length of braided nylon line is wrapped around the cup receiver in a continuous groove cut in the receiver. The ends of the line are attached to a series of calibrated springs. The calibrated springs are attached to the spring adjustment brackets which can be positioned on an extension bar so that a recording pen affixed to the line can be positioned at the edge of the chart paper mounted on the recording drum.

11.6.7 To determine the high-shear rheology of a clay-water suspension, a sample is poured into the cup to barely immerse the bob when it is lowered into position. The motor is switched on and the speed increased to 1100 rpm by turning the handwheel, manually or automatically, at a constant rate. The torque on the bob acts against the calibrated springs attached to the receiver, thus causing the recording pen to be deflected over an operable range of 180 mm.

Appendix A. Low-shear viscometer

A.1 A schematic diagram of the viscometer is shown in Fig. 1. Identification of the parts indicated by letters is shown below:

A: synchronous motor used to power the viscometer. It will operate either at the speed corresponding to the power supply or in the event of overloading or an extremely low voltage, will not rotate smoothly.

B: speed transmission driven by the motor. Depending on the model of viscometer used, either four or eight speeds are available.

C: on-off switch for the motor.

D: speed control knob.

E: instrument dial driven by the output shaft of the speed transmission. Two evenly graduated scales of 0 to 500 and 0 to 100 are superimposed over 312° of the dial's circumference. On the newer models, a single graduated scale of 0-100 will be noted. In any case, the 0-100 scale values are used in determining the viscosity in centipoise.

F: beryllium copper spring, one end of which is attached directly to the viscometer dial. The spring is calibrated to deflect through a specific number of degrees of angular rotation upon the application of a specific, fixed torque. The relationship of applied torque to the angular deflection is linear and depends on the particular model, being the same for the same model type.

G: pointer, made from nonmagnetic alloy attached to the collet on which the beryllium copper spring F is mounted. The pointer is free to rotate with respect to the dial, below the "zero" and above the "100" and "500" marks to prevent overloading the spring.

H: pivot shaft upon which is mounted the collet, holding both the pointer G and spring.

I: jewel support arm connected directly to the dial and to the gear transmission to the motor.

J: pivot point mounted on the pivot shaft.

K: 3-56 left-hand thread on the lower portion of the pivot shaft.

L: spindle, either disk or cylinder shaped attached to the pivot shaft at K.

M: immersion mark on the shaft of each spindle.

N: container for the specimen (not usually provided with the instrument).

O: bubble level.

P: clutch lever; if depressed, this will lift the dial and fix it to the pointer.

Appendix B. High-shear viscometer

B.1 A schematic diagram of the viscometer is shown in Fig. 2. Identification of the parts indicated by letters is shown below:

A: extension bar.

B: spring adjustment brackets.

C: heavy spring.

D: light spring.

NOTE 7: Springs C and D are a set calibrated to measure a maximum torque of 1.0 Nm/m.

E: recording line.

F: recording pen.

G: recording paper grippers

H: recording drum.

J: drive spindle.

K: belt cover.

L: lever.

M: bob (rotor).

N: cup or stator.

O: cup holder assembly.

P: drum control handle.

Q: power switch.

R: control panel.

Your comments and suggestions on this procedure are earnestly requested and should be sent to the TAPPI Technical Divisions Administrator. ■